

CAPACITY	SYMBOL/ SERIAL NO.	CIRCUIT DIAGRAM
AC 230V, 60Hz		
18W x 2		

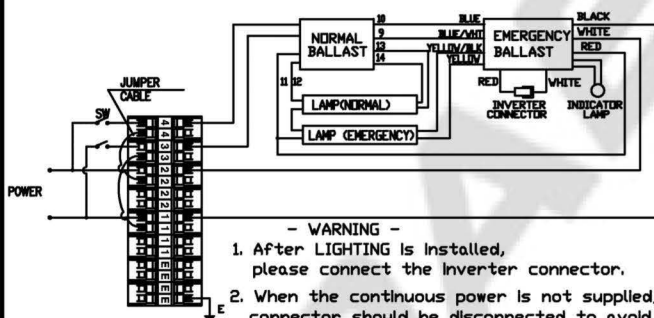

- WARNING -
1. After LIGHTING is installed, please connect the inverter connector.
 2. When the continuous power is not supplied, connector should be disconnected to avoid natural discharge of battery.
 3. On the circuit diagram, when connecting SW(SWITCH), remove JUMPER CABLE or IF SW is not connected, do not remove JUMPER CABLE.

CIRCUIT DIAGRAM

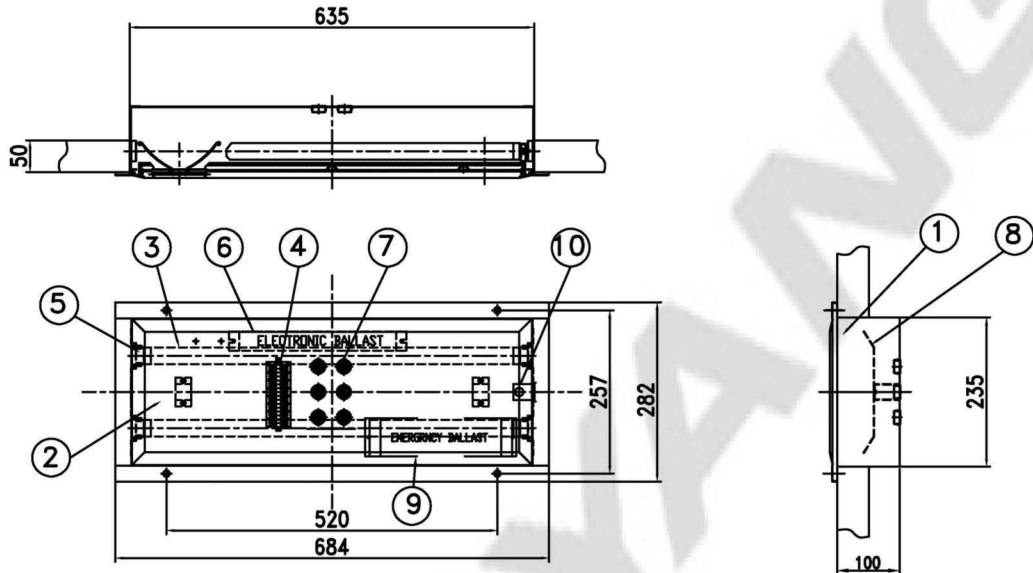
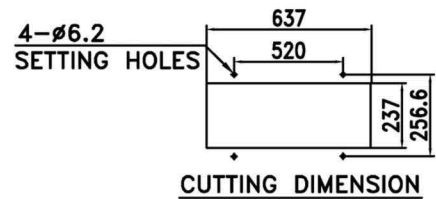

CUTTING DIMENSION

- NOTE -
1. DISCHARGING TIME : 3 hours
 2. FULL CHARGING TIME : 24 hours
 3. 1-LAMP OPERATION

* INDICATION LAMP COLOR STATUS

NO.	LED (RED)	MODE
1	Steady	Charging / Full charged
2	-	Discharge

* CAUTION

When cleaning globe, please wipe clean with a damp cloth.
Do not use thinner or (organic) solvent.

10	INDICATION LAMP	-	1		5	LAMP HOLDER	POLYCAR-BONATE	4	
9	EMERGENCY BALLAST	-	1		4	TERMINAL BLOCK	-	1	CLAMPING 8P (2.5sq)
8	REFLECTOR	STEEL	1		3	LAMP(3-BAND)	-	2	
7	CABLE INLET HOLES	NYLON	6	Ø16 SNAP BUSHING	2	GLOBE	POLYCAR-BONATE	1	
6	ELECTRONIC BALLAST	-	1		1	BODY	STEEL	1	
NO	NAME OF PARTS	MATERIAL	Q'TY	REMARKS	NO	NAME OF PARTS	MATERIAL	Q'TY	REMARKS

APPROVED	O. J. KWON	UNIT	MM
CHECKED		SCALE	N/S
DRAWING	B. I. KIM	COLOR	N-9.3
DATE	2019.03.03	IP	20

TITLE; FLUORESCENT CEILING LIGHT
(NO-GAP, FLUSH TYPE)
(BATTERY BACKUP)
FOR MARINE USE



MODEL NO.	FL220NF-0236EISNBbh12C840-A	WEIGHT	8.5 Kg
DWG NO.	L11150692	SHEET NO.	21

1) OPERATION / 작동

When AC power fails, the Emergency Ballast immediately switches to the discharging mode, operating one lamp at a reduced lumen output for a minimum of 90(18W) .

When AC power is restored, the Emergency Ballast automatically returns to the charging mode.

- Charging time : minimum 24hr
- Discharging time : FL18W, 1Lamp-90min

AC 전원이 공급되지 않을 때, 비상 안정기는 즉시 방전 모드로 전환됩니다. 한 개의 램프가 최소 90분(18W) 동안 감소된 광속 출력으로 작동하며 AC 전원이 다시 공급되면, 비상 안정기는 자동적으로 충전 모드로 전환됩니다.

- 충전시간 : 최소 24시간
- 방전시간 : FL18W 1Lamp-90분

2) INDICATOR LAMP COLOR STATUS / 상태 표시 램프 색상

The indicator shows the degree of battery charging and discharging.

표시기는 배터리 충전 및 방전 상태를 보여줍니다.

No.	LED(RED)	MODE
1	LAMP ON	CHARGING / FULL CHARGED
2	LAMP OFF	DISCHARGING / FULL DISCHARGED

순번.	표시램프(적색)	작동모드
1	램프 점등	충전 중 /완전충전
2	램프 소등	방전 중 /방전 완료

3) DIRECTIONS FOR THE USE / 사용 시 주의사항

Wiring should be implemented strictly following manufacturer's drawing; any damage caused by improper wiring is not covered by warranty policy.

Test of emergency condition, such as battery discharging time test, should be executed when the battery is fully charged.

The battery connector must be disconnected from battery during construction & test period of vessel, where frequent cut-off of the power source could be happened.

And, Please connect a separate battery connector just before the sea-trial or when normal operation only.

Otherwise, the performance and lifespan of the battery will be significantly deteriorated.

결선은 공급자의 도면에 따라서 엄격하게 시행되어야 하며, 부적절한 결선으로 야기된 위험은 보증 정책이 적용되지 않습니다.

배터리 방전시간 시험과 같은 비상상태에서의 시험은 배터리가 완전 충전되었을 때 실행해야 합니다.

배터리는 커넥터는 전원이 자주 차단되는 선박의 공사 & 시험기간 동안에는 배터리로 부터 분리해야 합니다. 그리고, 분리된 배터리 커넥터는 시운전 직전 또는 정상 사용 시에 연결하십시오. 그렇지 않을 경우, 배터리의 성능과 수명은 현격하게 저하 됩니다.)

APPROVED	B. K. KIM	UNIT	MM
CHECKED		SCALE	N/S
DRAWING	B. I. KIM	COLOR	-
DATE	2016.02.17	IP	-

TITLE;

**BATTERY BACKUP
Information Sheet
(Bodine Em'cy Ballast / BDL60u)**



SHEET NO. 21-A